



KRAFTSTOFFMANAGEMENT-SYSTEM



ABGABEEINHEITEN



KITS



PUMPEN



ZÄHLER



ZAPFVENTIL

# ST 200 AC

## MERKMALE

- ROBUSTER METALLRAHMEN
- SOFORT EINSATZBEREIT
- EINFACH TRANSPORTIERBAR
- LEISTUNGSSTARK

Die Abgabeeinheit PIUSI ST 200 AC ermöglicht dank der beiden integrierten selbstansaugenden Drehschieberpumpen vom Typ E120 das Betanken mit hohen Volumenströmen. Die mit einem Bypassventil und einer Dichtung mit erhöhter Zuverlässigkeit ausgestattete Abgabeeinheit funktioniert auch bei niedrigen Arbeitstemperaturen und unter allen Bedingungen auf Baustellen. Der mechanische Ovalrad-Durchflussmesser gewährleistet hohe Präzision (auf Anfrage lieferbar). Auf Anfrage zur einfacheren Handhabung auch mit Rädern und Griff lieferbar.

### LEISTUNGSPARAMETER

BIS ZU

**200 L/MIN**

VOLUMENSTROM

**AC**

**DAUERBETRIEB**

STROMVERSORGUNG



ST 200 AC



PRAKTISCHES KIT: AUSFÜHRUNG MIT RÄDERN UND GRIFF

### VERPACKUNG

CODE	GEWICHT		VERPACKUNG		
	KG	LBS	MM	ZOLL	STCK./KARTON
FO0315000	46	101	587X395X420	23,1X15,6X16,5	1
F16860000	-	-	-	-	-



FILTERUNG



TANKÜBERWACHUNG



SCHLAUCHAUFRÖLLER



ZUBEHÖR



MERCHANDISE



ANY BIODIESEL



LUFT



FROSTSCHUTZ



AdBlue®



BIODIESEL



DIESEL



LEBENSM.



BENZIN



SCHMIERM.



KEROSIN



ÖL



WASSER



WISCHERFLÜSS.

## KENNLINIEN

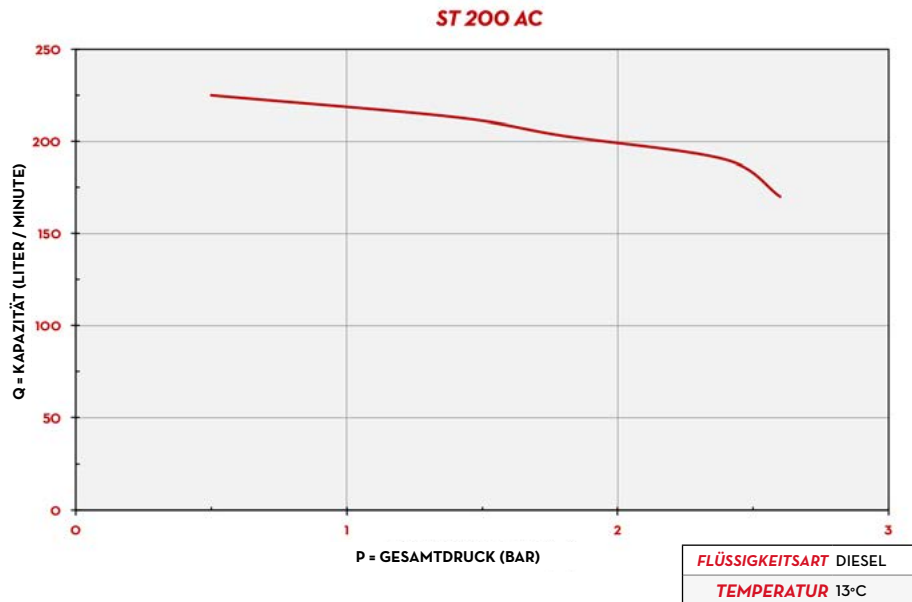

## LIEFERUMFANG

- ST 200 AC-EINHEIT
- BEDIENUNGSANLEITUNG

## EINZELHEITEN



EIN/AUS-SCHALTER

## ABMESSUNGEN

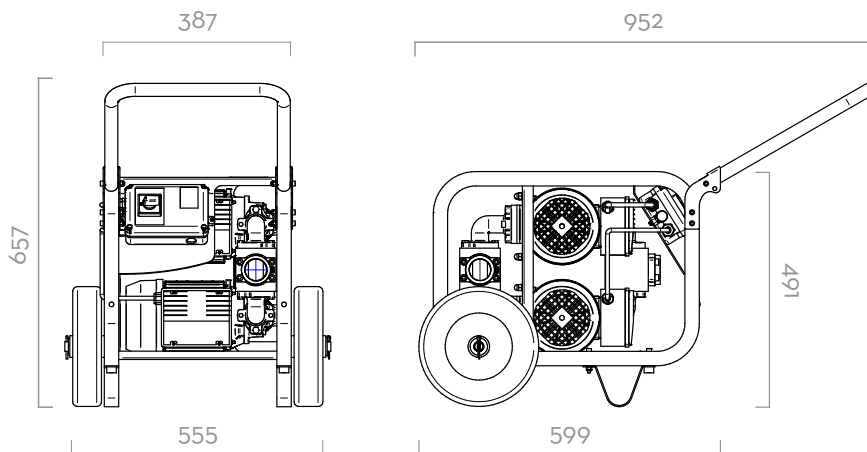

Maße in Millimetern

## MATERIALIEN

- GEHÄUSE: GUSSEISEN
- ROTOR: SINTERSTAHL
- FLÜGELZELLEN: ACETALHARZ
- DICHTUNGEN: VITON
- WELLE: STAHL

## TECHNISCHE DATEN

CODE	BESCHREIBUNG	FLÜSSIGKEITSART	VOLUMENSTROM		SPANNUNG			PUMPE		MAX. DRUCK	EINLASS
			L/MIN	GPM	AC V/ HZ DC VOLT	STROM. WATT	AMP. MAX.	TYP	N°	BAR	BSP
FO0315000	ST 200 BASIC	D	200	52,7	230/50	2050	10	E 120	2	2,5	1" 1/2
F16860000	HANDY KIT (MANIGLIA + WHEELS)	D	-	-	-	-	-	-	-	-	-